

**DATE RELEASED**

07-14-21

DATE EFFECTIVE

07-14-21

SUBJECT

Nose Fork Fatigue Cracks

EFFECTIVITY**MODEL-** Ranger R7**SERIAL NO:** ALL AIRCRAFT WITH THE 810601 NOSE FORK (10131-10186)**REASON**

Fatigue cracks have been reported in the field that may result in a complete nose fork failure, if not inspected.

Further investigation and analysis is being completed for a comprehensive, corrective action.

REQUIRED ACTION

Inspect nose fork for cracks

TYPE OF MAINTENANCE

Low

MINIMUM LEVEL OF CERTIFICATION

Owner

TIME OF COMPLIANCE

Mandatory before further flight, then in 10 hr. intervals.

METHOD OF COMPLIANCE

Inspect nose fork for cracks in the areas shown in Figure 1 and Figure 2. If any cracks are present, DO NOT continue flying—Contact Vashon Aircraft for corrective action until a subsequent bulletin is released.

LABOR REQUIRED:

none at this time.

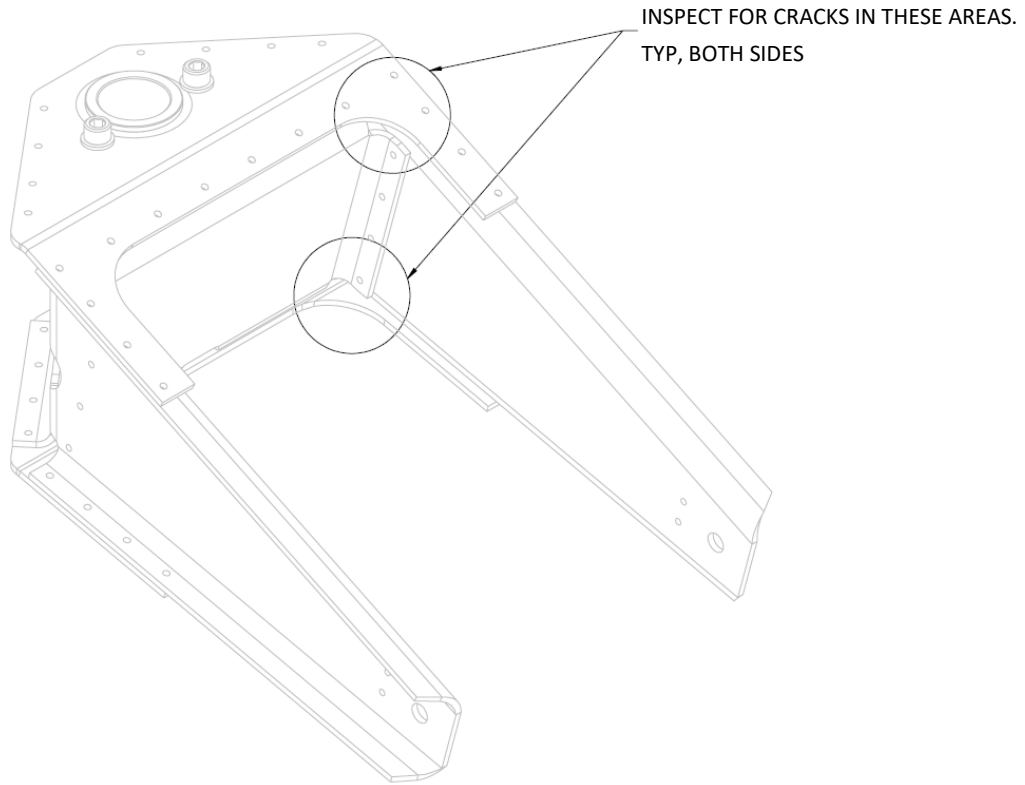

Figure 1

INSPECT FOR CRACKS IN THESE AREAS.
TYP, BOTH SIDES

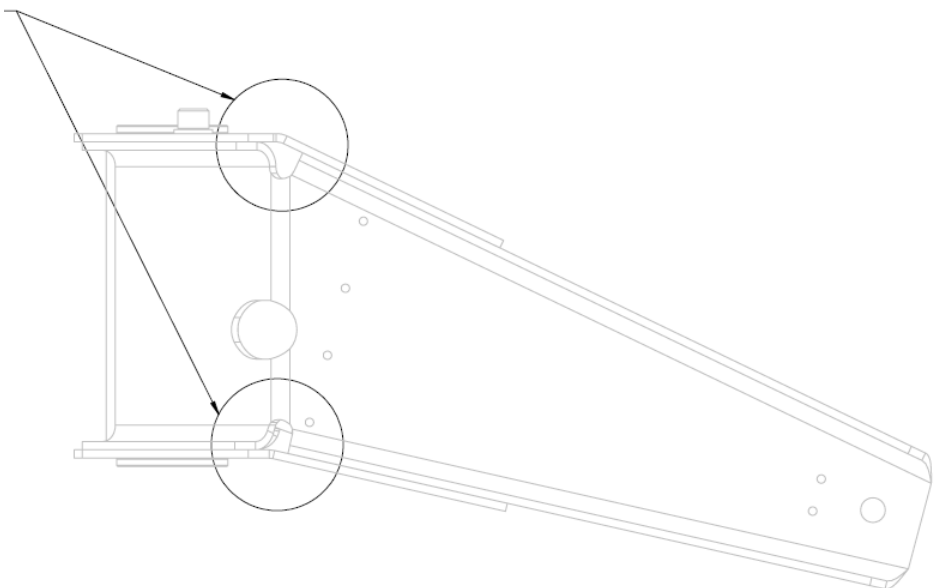

Figure 2